

CARFAX Report

US \$44.99

2023 Tesla Model Y Long Range

19,698 mi | VIN: 7SAYGDEE2PF901590

Vehicle Details

CARFAX HAS THE MOST ACCIDENT & DAMAGE INFORMATION



BRANDED TITLE

Salvage

CARFAX VALUE \$24,270

Update Trim & Options

1 CARFAX 1-Owner Vehicle

Personal Lease Vehicle

Last Owned in California

7 Detailed Records Available

This CARFAX Vehicle History Report is based only on information supplied to CARFAX and available as of 6/13/26 at 11:57:14 AM (CDT). Other information about this vehicle, including problems, may not have been reported to CARFAX. Use this report as one important tool, along with a vehicle inspection and test drive, to make a better decision about your next used car.

CARFAX Accident / Damage History

Not all accidents / issues are reported to CARFAX

Event 1

05/16/2025

TOTAL LOSS VEHICLE

- Accident reported
- Vehicle declared a total loss by an insurance company

View More Details

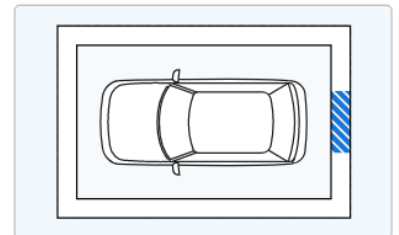

Event 2

05/30/2025

Damage reported: minor to moderate damage

View More Details

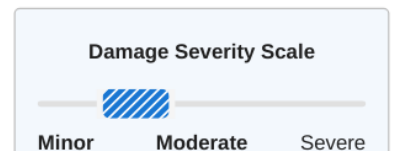

[View More Details >](#)

Minor

Moderate

Severe

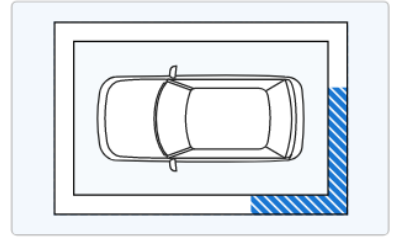

CARFAX History-Based Value

\$24,270

CARFAX Retail Value

History events affecting this vehicle's value

- 1-Owner Vehicle
- Salvage Brand

Personal Vehicle

CARFAX Additional History

Not all accidents / issues are reported to CARFAX

Owner 1

Total Loss

Total Loss Reported: 05/16/2025.

[Total Loss Reported](#)

Structural Damage

CARFAX recommends that you have this vehicle inspected by a collision repair specialist.



Airbag Deployment

No airbag deployment reported to CARFAX.



Odometer Check

No indication of an odometer rollback.



Accident / Damage

DMV title problems reported. Accident reported: 05/16/2025. Damage reported: 05/30/2025.

[Severe Damage](#)

Manufacturer Recall

Check with an authorized Tesla dealer for any open recalls.

Ask Your Dealer

Basic Warranty

Original manufacturer warranty likely voided by manufacturer.

Warranty Voided

CARFAX Title History

Owner 1

Damage Brands

Salvage | Junk | Rebuilt | Fire | Flood | Hail | Lemon

Alert!
Problem Found

Odometer Brands

Not Actual Mileage | Exceeds Mechanical Limits

No Problem

ALERT! ... Department of Motor Vehicles (DMV). This vehicle is not eligible for ...



ALERT! - Severe problems were reported by a state Department of Motor Vehicles (DMV). This vehicle does not qualify for the CARFAX Buyback Guarantee.



Ownership History

The number of owners is estimated

Owner 1

Year purchased	2023
Type of owner	Personal Lease
Estimated length of ownership	1 yr. 9 mo.
Owned in the following states/provinces	California
Estimated miles driven per year	11,485/yr
Last reported odometer reading	19,698



Detailed History

[Glossary](#)



Owner 1

Purchased: 2023

Personal Lease Vehicle

11,485 mi/yr

Date	Mileage	Source	Comments
10/12/2023	15	California Motor Vehicle Dept. Glendale, CA	Odometer reading reported
10/28/2023		California Motor Vehicle Dept. Glendale, CA	Title issued or updated - First owner reported - Titled or registered as personal lease vehicle - Loan or lien reported
05/16/2025		Damage Report	TOTAL LOSS VEHICLE - Accident reported - Vehicle declared a total loss by an insurance company - Damage to rear

CARFAX HAS THE MOST ACCIDENT & DAMAGE INFORMATION



There are many reasons an insurance company will declare a vehicle a total loss. Have this vehicle inspected by a qualified technician before you buy. [Learn More](#)

05/30/2025



Damage Report

Damage reported: minor to moderate damage ⓘ

- Damage to left rear
- Damage to rear

-Damage to rear

CARFAX HAS THE MOST ACCIDENT & DAMAGE INFORMATION

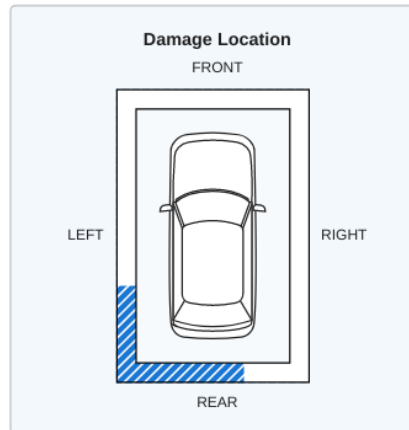
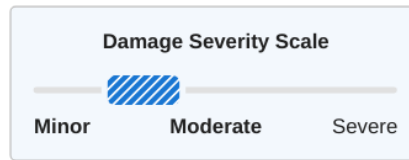

07/15/2025		California Motor Vehicle Dept.	Title or registration issued to insurance company
07/15/2025	19,698	California Motor Vehicle Dept. Gardena, CA	SALVAGE TITLE/CERTIFICATE ISSUED
07/17/2025		Damage Report	SALVAGE TITLE/CERTIFICATE ISSUED

Have Questions? Consumers, please visit our Help Center at www.carfax.com. Dealers or Subscribers, please visit our Help Center at www.carfaxonline.com.

Accident Indicator

CARFAX receives information about accidents in all 50 states, the District of Columbia and Canada.

Not every accident is reported to CARFAX. As details about the accident become available, those additional details are added to the CARFAX Vehicle History Report. CARFAX recommends that you have this vehicle inspected by a qualified mechanic.

- According to the National Safety Council, Injury Facts, 2021 edition, 5% of the 276 million registered vehicles in the U.S. were involved in an accident in 2019. Over 77% of these were considered minor or moderate.
- This CARFAX Vehicle History Report is based only on information supplied to CARFAX and available as of 6/13/26 at 11:57:14 AM (CDT). Other information about this vehicle, including problems, may not have been reported to CARFAX. Use this report as one important tool, along with a vehicle inspection and test drive, to make a better decision about your next used car.

Damage Indicator

Damage can be a result of many different types of events. Examples include contact with objects (other cars, trees, traffic signs, road debris, etc), vandalism, or weather-related events. Not every damage event is reported to CARFAX. As details about the damage event become available, those additional details are added to the CARFAX Vehicle History Report. CARFAX recommends that you have this vehicle inspected by a qualified mechanic.

- This CARFAX Vehicle History Report is based only on information supplied to CARFAX and available as of 6/13/26 at 11:57:14 AM (CDT). Other information about this vehicle, including problems, may not have been reported to CARFAX. Use this report as one important tool, along with a vehicle inspection and test drive, to make a better decision about your next used car.

Damage Severity

Damage events result in one of the following severity levels:

- Minor: Generally, minor damage is cosmetic (including dents or scratches), may only require reconditioning, and typically does not compromise a vehicle's operation and/or safety.
- Moderate: Moderate damage may affect multiple components of the vehicle and may impair the vehicle's operation and/or safety.
- Severe: Severe damage usually affects multiple components of the vehicle and is likely to compromise the vehicle's operation and/or safety.

CARFAX recommends getting a pre-purchase inspection at a certified collision repair facility.

CARFAX recommends getting a pre-purchase inspection at a certified collision repair facility.

First Owner

When the first owner(s) obtains a title from a Department of Motor Vehicles as proof of ownership.

Ownership History

CARFAX defines an owner as an individual or business that possesses and uses a vehicle. Not all title transactions represent changes in ownership. To provide estimated number of owners, CARFAX proprietary technology analyzes all the events in a vehicle history. Estimated ownership is available for vehicles manufactured after 1991 and titled solely in the US including Puerto Rico. Dealers sometimes opt to take ownership of a vehicle and are required to in the following states: Maine, Massachusetts, New Jersey, Ohio, Oklahoma, Pennsylvania and South Dakota. Please consider this as you review a vehicle's estimated ownership history.

Salvage Title

A Salvage Title is issued on a vehicle damaged to the extent that the cost of repairing the vehicle exceeds approximately 75% of its pre-damage value. This damage threshold may vary by state. Some states treat Junk titles the same as Salvage but the majority use this title to indicate that a vehicle is not road worthy and cannot be titled again in that state. The following eleven states also use Salvage titles to identify stolen vehicles - AZ, FL, GA, IL, MD, MN, NJ, NM, NY, OK and OR.

Title Issued

A state issues a title to provide a vehicle owner with proof of ownership. Each title has a unique number. Each title or registration record on a CARFAX report does not necessarily indicate a change in ownership. In Canada, a registration and bill of sale are used as proof of ownership.

Total Loss Vehicle

An insurance or fleet company declares a vehicle a total loss when a claim exceeds approximately 75% of its pre-damage value or if the vehicle is stolen and not recovered. This damage threshold varies by company. These companies typically take possession and obtain the title. Not all total loss vehicles result in a DMV-reported branded title. This may occur when an insurance company's definition of a total loss is different than the state DMV's definition for a branded title or when the owner of the vehicle is a self-insured company, like a fleet or rental company.

Follow
Us:



facebook.com/CARFAX



[@CARFAXinc](https://twitter.com/CARFAXinc)



[About CARFAX](#)

CARFAX DEPENDS ON ITS SOURCES FOR THE ACCURACY AND RELIABILITY OF ITS INFORMATION. THEREFORE, NO RESPONSIBILITY IS ASSUMED BY CARFAX OR ITS AGENTS FOR ERRORS OR OMISSIONS IN THIS REPORT. CARFAX FURTHER EXPRESSLY DISCLAIMS ALL WARRANTIES, EXPRESS OR IMPLIED, INCLUDING ANY IMPLIED WARRANTIES OF MERCHANTABILITY OR FITNESS FOR A PARTICULAR PURPOSE.

© 2026 CARFAX, Inc., part of S&P Global. All rights reserved.

6/13/26 11:57:14 AM (CDT)

I have reviewed and received a copy of the CARFAX Vehicle History Report for this 2023 TESLA MODEL Y vehicle (VIN: 7SAYGDEE2PF901590), which is based on information supplied to CARFAX and available as of 6/13/26 at 12:57 PM (EDT).

Customer Signature

Date

Dealer Signature

Date