

## CARFAX History-Based Value Report

[Hide](#)

# \$27,150

CARFAX Retail Value

Retail
  Wholesale

### History events affecting this vehicle's value

- Personal Vehicle
- Total Loss

This CARFAX Vehicle History Report is based only on [information](#) supplied to CARFAX and available as of 3/20/25 at 6:15:11 AM (CDT). Other information about this vehicle, including problems, may not have been reported to CARFAX. Use this report as one important tool, along with a vehicle inspection and test drive, to make a better decision about your next used car.

## CARFAX Accident / Damage History

Not all accidents / issues are reported to CARFAX

### Event 1

12/04/2020

**Accident reported: minor damage**

- Airbags did not deploy

[View More Details >](#)

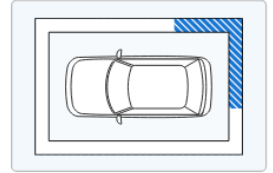
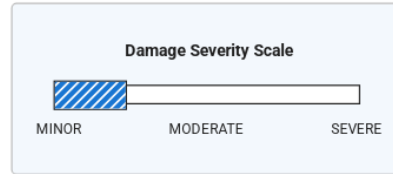

### Event 2

12/19/2024

**Accident reported: moderate damage**

- Vehicle involved in a rear-end collision

- Vehicle towed

- Airbags did not deploy

[View More Details >](#)

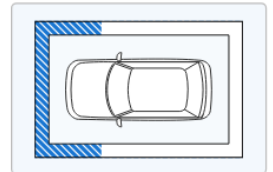
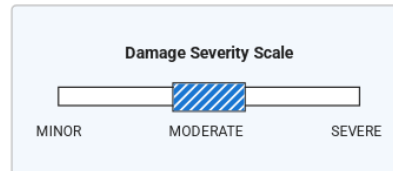

### Event 3

02/21/2025

**TOTAL LOSS VEHICLE**

[View More Details >](#)

## CARFAX Additional History

Not all accidents / issues are reported to CARFAX

Owner 1

Owner 2

### Total Loss

Total Loss Reported: 02/21/2025.

No Issues Reported

[Total Loss Reported](#)

### Structural Damage

CARFAX recommends that you have this vehicle inspected by a collision repair specialist.

No Issues Reported

No Issues Reported

### Airbag Deployment

No airbag deployment reported to CARFAX.

No Issues Reported

No Issues Reported



### Odometer Check

<b>Odometer Check</b> ⓘ No indication of an odometer rollback.	✔ No Issues Indicated	✔ No Issues Indicated
<b>Accident / Damage</b> ⓘ Accidents reported: 12/04/2020 and 12/19/2024.	<a href="#">Accident Reported</a>	<a href="#">Accident Reported</a>
<b>Manufacturer Recall</b> ⓘ No open recalls reported to CARFAX.	✔ No Recalls Reported	✔ No Recalls Reported
<b>Basic Warranty</b> ⓘ <a href="#">Original warranty</a> estimated to have expired.	<b>Warranty Expired</b>	<b>Warranty Expired</b>

<b>CARFAX</b> Title History CARFAX guarantees the information in this section	Owner 1	Owner 2
<b>Damage Brands</b> ⓘ Salvage   Junk   Rebuilt   Fire   Flood   Hail   Lemon	✔ <b>Guaranteed</b> No Problem	✔ <b>Guaranteed</b> No Problem
<b>Odometer Brands</b> ⓘ Not Actual Mileage   Exceeds Mechanical Limits	✔ <b>Guaranteed</b> No Problem	✔ <b>Guaranteed</b> No Problem
 <b>GUARANTEED</b> - None of these title problems were reported by a U.S. state Department of Motor Vehicles (DMV). If you find that any of these title problems were reported by a DMV and not included in this report, you may qualify. <a href="#">View Terms</a>   <a href="#">View Certificate</a>		

<b>CARFAX</b> Ownership History The number of owners is estimated	Owner 1	Owner 2
Year purchased	2020	2023
Type of owner	Personal	Personal
Estimated length of ownership	2 yrs. 9 mo.	1 yr. 10 mo.
Owned in the following states/provinces	Texas	Texas
Estimated miles driven per year	18,142/yr	8,755/yr
Last reported odometer reading	51,128	63,835

**CARFAX** Detailed History [Glossary](#)

 <b>Owner 1</b> Purchased: 2020			Personal Vehicle 18,142 mi/yr
Date	Mileage	Source	Comments
12/14/2019		NICB	<b>Vehicle manufactured and shipped to original dealer</b>
01/29/2020	74	Texas Motor Vehicle Dept. Van Alstyne, TX Title #04337043850250032	<b>Title issued or updated</b> - First owner reported - Titled or registered as personal vehicle - Loan or lien reported - Vehicle color noted as Black
12/04/2020		Damage Report	 <b>Accident reported: minor damage</b> ⓘ - Damage to rear - Damage to right rear - Airbags did not deploy

-Airbags did not deploy



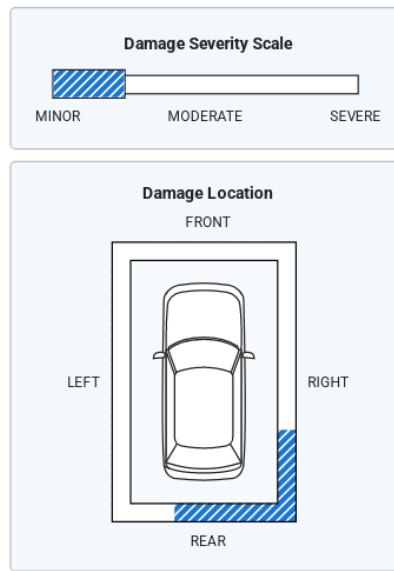



### CARFAX HAS THE MOST ACCIDENT & DAMAGE INFORMATION



12/30/2021	34,576	Service Facility	<b>Vehicle serviced</b> - Safety inspection performed
12/30/2021		Texas Inspection Station	<b>Passed safety inspection</b>
01/01/2022		Texas Motor Vehicle Dept. Van Alstyne, TX Title #04337043850250032	<b>Registration issued or renewed</b> - Loan or lien reported - Passed safety inspection - Vehicle color noted as Black
11/19/2022		Texas Motor Vehicle Dept.	<b>Vehicle purchase reported</b>
11/22/2022	51,098	Audi McKinney Mckinney, TX 972-390-1200 audimckinney.com/ ★ 4.8 / 5.0 <a href="#">18 Verified Reviews</a>	<b>Vehicle offered for sale</b>
11/25/2022	51,128	Texas Inspection Station Van Alstyne, TX	<b>Passed emissions inspection</b>
12/06/2022		Texas Motor Vehicle Dept. Van Alstyne, TX Title #28695344898006787	<b>Title issued or updated</b> - Loan or lien released - Vehicle color noted as Black

**Owner 2** Personal Vehicle  
Purchased: 2023 8,755 mi/yr

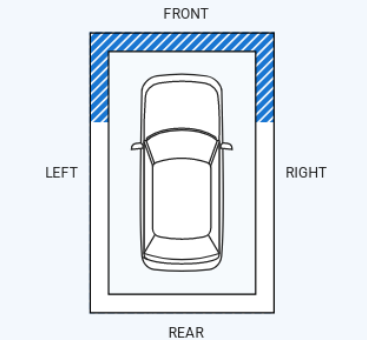
Date	Mileage	Source	Comments
02/17/2023	51,130	Texas Motor Vehicle Dept. San Angelo, TX Title #04336744964250244	<b>Title issued or updated</b> - New owner reported - Loan or lien reported - Vehicle color noted as Black
05/31/2023	55,008	Rick Henry's Auto Service San Angelo, TX 325-653-3583 ★ 4.7 / 5.0 <a href="#">21 Verified Reviews</a> ❤️ 9 Customer Favorites	<b>Vehicle serviced</b> - Body lubricated - Fluids checked - Oil and filter changed
01/05/2024	59,384	Texas Inspection Station	<b>Passed safety inspection</b>

<p>01/05/2024</p>	<p>Texas Motor Vehicle Dept. San Angelo, TX Title #04336744964250244</p>	<p><b>Registration issued or renewed</b> - Loan or lien reported - Passed safety inspection - Vehicle color noted as Black</p>
<p>02/20/2024</p>	<p>59,957 Tom's Tire Pros San Angelo San Angelo, TX 325-655-9555 tomstirepros.com/ ★ 4.9 / 5.0 <a href="#">45 Verified Reviews</a> ♥ 25 Customer Favorites</p>	<p> <b>Vehicle serviced</b> - Oil and filter changed</p>
<p>12/19/2024</p> <p><b>CARFAX HAS THE MOST ACCIDENT &amp; DAMAGE INFORMATION</b></p> 	<p>Damage Report</p>	<p> <b>Accident reported: moderate damage</b> ⓘ</p> <ul style="list-style-type: none"> <li>- Vehicle involved in a rear-end collision</li> <li>- Damage to left front</li> <li>- Damage to right front</li> <li>- Damage to front</li> <li>- Vehicle towed</li> <li>- Airbags did not deploy</li> </ul> <div data-bbox="847 705 1246 846"> <p><b>Damage Severity Scale</b></p>  </div> <div data-bbox="847 862 1246 1267"> <p><b>Damage Location</b></p>  </div>
<p>01/03/2025</p>	<p>Texas Motor Vehicle Dept.</p>	<p><b>Vehicle purchase reported</b></p>
<p>01/31/2025</p>	<p>Texas Motor Vehicle Dept. San Angelo, TX Title #28695345685005088</p>	<p><b>Title issued or updated</b> - Loan or lien released - Vehicle color noted as Black</p>
<p>02/21/2025</p>	<p>Damage Report</p> 	<p> <b>TOTAL LOSS VEHICLE</b></p> <div data-bbox="839 1630 1497 1749"> <p>There are many reasons an insurance company will declare a vehicle a total loss. Have this vehicle inspected by a qualified technician before you buy. <a href="#">Learn More</a></p> </div>
<p>02/21/2025</p>	<p>63,835 Texas Motor Vehicle Dept. Florence, TX Title #01130945699250076</p>	<p><b>Title or registration issued to insurance company</b> - Vehicle color noted as Black</p>
<p>03/20/2025</p>	<p>Audi</p>	<p><b>Connect Service available with subscription</b> <b>Connect offers services to enhance navigation, infotainment, and peace of mind</b> <a href="#">Learn more</a></p>

**Accident Indicator**

CARFAX receives information about accidents in all 50 states, the District of Columbia and Canada.

Not every accident is reported to CARFAX. As details about the accident become available, those additional details are added to the CARFAX Vehicle History Report. CARFAX recommends that you have this vehicle inspected by a qualified mechanic.

- According to the National Safety Council, Injury Facts, 2021 edition, 5% of the 276 million registered vehicles in the U.S. were involved in an accident in 2019. Over 77% of these were considered minor or moderate.
- This CARFAX Vehicle History Report is based only on information supplied to CARFAX and available as of 3/20/25 at 6:15:11 AM (CDT). Other information about this vehicle, including problems, may not have been reported to CARFAX. Use this report as one important tool, along with a vehicle inspection and test drive, to make a better decision about your next used car.

**Damage Severity**

Damage events result in one of the following severity levels:

- Minor: Generally, minor damage is cosmetic (including dents or scratches), may only require reconditioning, and typically does not compromise a vehicle's operation and/or safety.
- Moderate: Moderate damage may affect multiple components of the vehicle and may impair the vehicle's operation and/or safety.
- Severe: Severe damage usually affects multiple components of the vehicle and is likely to compromise the vehicle's operation and/or safety.

CARFAX recommends getting a pre-purchase inspection at a certified collision repair facility.

**First Owner**

When the first owner(s) obtains a title from a Department of Motor Vehicles as proof of ownership.

**New Owner Reported**

When a vehicle is sold to a new owner, the Title must be transferred to the new owner(s) at a Department of Motor Vehicles.

**Ownership History**



CARFAX defines an owner as an individual or business that possesses and uses a vehicle. Not all title transactions represent changes in ownership. To provide estimated number of owners, CARFAX proprietary technology analyzes all the events in a vehicle history. Estimated ownership is available for vehicles manufactured after 1991 and titled solely in the US including Puerto Rico. Dealers sometimes opt to take ownership of a vehicle and are required to in the following states: Maine, Massachusetts, New Jersey, Ohio, Oklahoma, Pennsylvania and South Dakota. Please consider this as you review a vehicle's estimated ownership history.

**Title Issued**

A state issues a title to provide a vehicle owner with proof of ownership. Each title has a unique number. Each title or registration record on a CARFAX report does not necessarily indicate a change in ownership. In Canada, a registration and bill of sale are used as proof of ownership.

**Total Loss Vehicle**

An insurance or fleet company declares a vehicle a total loss when a claim exceeds approximately 75% of its pre-damage value or if the vehicle is stolen and not recovered. This damage threshold varies by company. These companies typically take possession and obtain the title. Not all total loss vehicles result in a DMV-reported branded title. This may occur when an insurance company's definition of a total loss is different than the state DMV's definition for a branded title or when the owner of the vehicle is a self-insured company, like a fleet or rental company.

Follow Us:  [facebook.com/CARFAX](https://facebook.com/CARFAX)  [@CARFAXinc](https://twitter.com/CARFAXinc)  [About CARFAX](#)

CARFAX DEPENDS ON ITS SOURCES FOR THE ACCURACY AND RELIABILITY OF ITS INFORMATION. THEREFORE, NO RESPONSIBILITY IS ASSUMED BY CARFAX OR ITS AGENTS FOR ERRORS OR OMISSIONS IN THIS REPORT. CARFAX FURTHER EXPRESSLY DISCLAIMS ALL WARRANTIES, EXPRESS OR IMPLIED, INCLUDING ANY IMPLIED WARRANTIES OF MERCHANTABILITY OR FITNESS FOR A PARTICULAR PURPOSE.

© 2025 CARFAX, Inc., part of S&P Global. All rights reserved.  
3/20/25 6:15:11 AM (CDT)

**I have reviewed and received a copy of the CARFAX Vehicle History Report for this 2019 AUDI S5 SPORTBACK vehicle (VIN: WAUB4CF50KA079634), which is based on information supplied to CARFAX and available as of 3/20/25 at 7:15 AM (EDT).**

\_\_\_\_\_  
Customer Signature

\_\_\_\_\_  
Date

\_\_\_\_\_  
Dealer Signature

\_\_\_\_\_  
Date



\$27,150

CARFAX Retail Value

Retail  Wholesale

History events affecting this vehicle's value

- Personal Vehicle
- Total Loss



Vehicle History Report™

US \$44.99

2019 AUDI S5 SPORTBACK 3.0T QUATTRO PREMIUM PLUS

VIN: WAUB4CF50KA079634  
HATCHBACK 4 DR  
3.0L V6 F DOHC 24V  
GASOLINE  
ALL WHEEL DRIVE

- Total loss vehicle >
- 3 Service history records >
- 2 Previous owners >
- Personal vehicle >
- Last owned in Texas >
- 63,835 Last reported odometer reading >

CARFAX HAS THE MOST ACCIDENT & DAMAGE INFORMATION



This CARFAX Vehicle History Report is based only on [information](#) supplied to CARFAX and available as of 3/20/25 at 6:15:11 AM (CDT). Other information about this vehicle, including problems, may not have been reported to CARFAX. Use this report as one important tool, along with a vehicle inspection and test drive, to make a better decision about your next used car.



Accident / Damage History

Not all accidents / issues are reported to CARFAX

Event 1

12/04/2020

Accident reported: minor damage ⓘ

- Airbags did not deploy

[View More Details >](#)

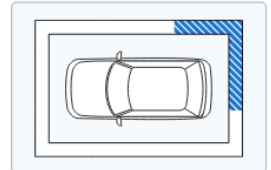
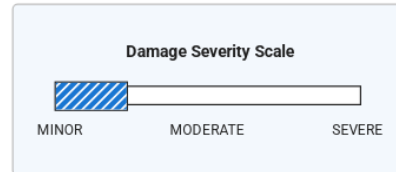

Event 2

12/19/2024

Accident reported: moderate damage ⓘ

- Vehicle involved in a rear-end collision  
- Vehicle towed  
- Airbags did not deploy

[View More Details >](#)

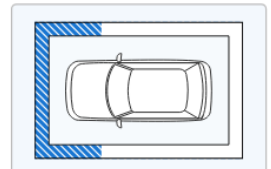
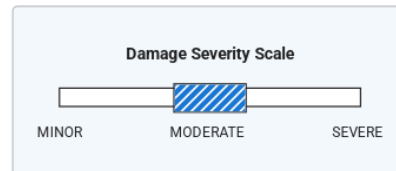

Event 3

02/21/2025

TOTAL LOSS VEHICLE

[View More Details >](#)

<b>CARFAX</b> Additional History Not all accidents / issues are reported to CARFAX	Owner 1	Owner 2
<b>Total Loss</b> ⓘ Total Loss Reported: 02/21/2025.	✔ No Issues Reported	<a href="#">Total Loss Reported</a>
<b>Structural Damage</b> ⓘ CARFAX recommends that you have this vehicle inspected by a collision repair specialist.	✔ No Issues Reported	✔ No Issues Reported
<b>Airbag Deployment</b> ⓘ No airbag deployment reported to CARFAX.	✔ No Issues Reported	✔ No Issues Reported
<b>Odometer Check</b> ⓘ No indication of an odometer rollback.	✔ No Issues Indicated	✔ No Issues Indicated
<b>Accident / Damage</b> ⓘ Accidents reported: 12/04/2020 and 12/19/2024.	<a href="#">Accident Reported</a>	<a href="#">Accident Reported</a>
<b>Manufacturer Recall</b> ⓘ No open recalls reported to CARFAX.	✔ No Recalls Reported	✔ No Recalls Reported
<b>Basic Warranty</b> ⓘ <a href="#">Original warranty</a> estimated to have expired.	<b>Warranty Expired</b>	<b>Warranty Expired</b>

<b>CARFAX</b> Title History CARFAX guarantees the information in this section	Owner 1	Owner 2
<b>Damage Brands</b> ⓘ Salvage   Junk   Rebuilt   Fire   Flood   Hail   Lemon	✔ <b>Guaranteed</b> No Problem	✔ <b>Guaranteed</b> No Problem
<b>Odometer Brands</b> ⓘ Not Actual Mileage   Exceeds Mechanical Limits	✔ <b>Guaranteed</b> No Problem	✔ <b>Guaranteed</b> No Problem







**GUARANTEED** - None of these title problems were reported by a U.S. state Department of Motor Vehicles (DMV). If you find that any of these title problems were reported by a DMV and not included in this report, you may qualify.  
[View Terms](#) | [View Certificate](#)

<b>CARFAX</b> Ownership History The number of owners is estimated	Owner 1	Owner 2
Year purchased	2020	2023
Type of owner	Personal	Personal
Estimated length of ownership	2 yrs. 9 mo.	1 yr. 10 mo.
Owned in the following states/provinces	Texas	Texas
Estimated miles driven per year	18,142/yr	8,755/yr
Last reported odometer reading	51,128	63,835

**CARFAX** Detailed History [Glossary](#)

<b>Owner 1</b> Purchased: 2020	Personal Vehicle 18,142 mi/yr
-----------------------------------	----------------------------------

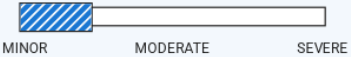
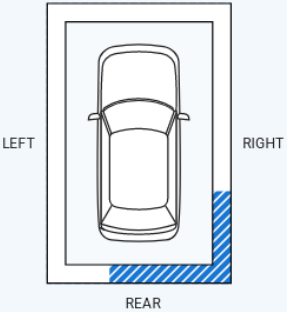
Date	Mileage	Source	Comments
------	---------	--------	----------

Date	Mileage	Source	Comments
12/14/2019		NICB	<b>Vehicle manufactured and shipped to original dealer</b>
01/29/2020	74	Texas Motor Vehicle Dept. Van Alstyne, TX Title #04337043850250032	<b>Title issued or updated</b> - First owner reported - Titled or registered as personal vehicle - Loan or lien reported - Vehicle color noted as Black
12/04/2020		Damage Report	 <b>Accident reported: minor damage</b> ⓘ - Damage to rear - Damage to right rear - Airbags did not deploy
			<div data-bbox="847 515 1246 656"> <p><b>Damage Severity Scale</b></p>  <p>MINOR      MODERATE      SEVERE</p> </div> <div data-bbox="847 667 1246 1077"> <p><b>Damage Location</b></p>  </div>
12/30/2021	34,576	Service Facility	 <b>Vehicle serviced</b> - Safety inspection performed
12/30/2021		Texas Inspection Station	<b>Passed safety inspection</b>
01/01/2022		Texas Motor Vehicle Dept. Van Alstyne, TX Title #04337043850250032	<b>Registration issued or renewed</b> - Loan or lien reported - Passed safety inspection - Vehicle color noted as Black
11/19/2022		Texas Motor Vehicle Dept.	<b>Vehicle purchase reported</b>
11/22/2022	51,098	Audi McKinney Mckinney, TX 972-390-1200 audimckinney.com/ ★ 4.8 / 5.0 <a href="#">18 Verified Reviews</a> ✓	<b>Vehicle offered for sale</b>
11/25/2022	51,128	Texas Inspection Station Van Alstyne, TX	<b>Passed emissions inspection</b>
12/06/2022		Texas Motor Vehicle Dept. Van Alstyne, TX Title #28695344898006787	<b>Title issued or updated</b> - Loan or lien released - Vehicle color noted as Black

**CARFAX HAS THE MOST  
ACCIDENT & DAMAGE  
INFORMATION**

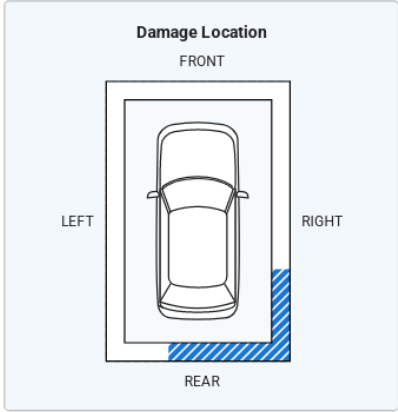
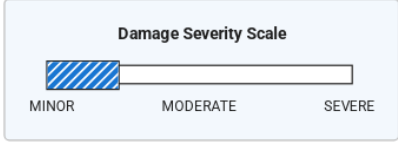

**Vehicle serviced**  
- Safety inspection performed

**Passed safety inspection**

**Registration issued or renewed**  
- Loan or lien reported  
- Passed safety inspection  
- Vehicle color noted as Black

**Vehicle purchase reported**

**Vehicle offered for sale**

★ 4.8 / 5.0 [18 Verified Reviews](#) ✓









**Passed emissions inspection**

**Title issued or updated**  
- Loan or lien released  
- Vehicle color noted as Black

 **Owner 2**  
Purchased: 2023

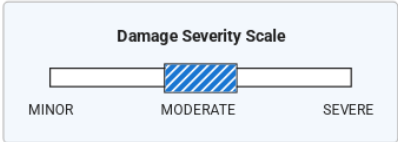
Personal Vehicle  
8,755 mi/yr

Date	Mileage	Source	Comments
------	---------	--------	----------

Date	Mileage	Source	Comments
02/17/2023	51,130	Texas Motor Vehicle Dept. San Angelo, TX Title #04336744964250244	<b>Title issued or updated</b> - New owner reported - Loan or lien reported - Vehicle color noted as Black
05/31/2023	55,008	Rick Henry's Auto Service San Angelo, TX 325-653-3583 ★ 4.7 / 5.0 <a href="#">21 Verified Reviews</a> ✓ ❤️ 9 Customer Favorites	 <b>Vehicle serviced</b> - Body lubricated - Fluids checked - Oil and filter changed
01/05/2024	59,384	Texas Inspection Station	<b>Passed safety inspection</b>
01/05/2024		Texas Motor Vehicle Dept. San Angelo, TX Title #04336744964250244	<b>Registration issued or renewed</b> - Loan or lien reported - Passed safety inspection - Vehicle color noted as Black
02/20/2024	59,957	Tom's Tire Pros San Angelo San Angelo, TX 325-655-9555 tomstirepros.com/ ★ 4.9 / 5.0 <a href="#">45 Verified Reviews</a> ✓ ❤️ 25 Customer Favorites	 <b>Vehicle serviced</b> - Oil and filter changed
12/19/2024		Damage Report	 <b>Accident reported: moderate damage</b> ⓘ - Vehicle involved in a rear-end collision - Damage to left front - Damage to right front - Damage to front - Vehicle towed - Airbags did not deploy
<p><b>CARFAX HAS THE MOST ACCIDENT &amp; DAMAGE INFORMATION</b></p> 		 	
01/03/2025		Texas Motor Vehicle Dept.	<b>Vehicle purchase reported</b>
01/31/2025		Texas Motor Vehicle Dept. San Angelo, TX Title #28695345685005088	<b>Title issued or updated</b> - Loan or lien released - Vehicle color noted as Black
02/21/2025		Damage Report	 <b>TOTAL LOSS VEHICLE</b>
			There are many reasons an insurance company will declare a vehicle a total loss. Have this vehicle inspected by a qualified technician before you buy. <a href="#">Learn More</a>



02/21/2025	63,835	Texas Motor Vehicle Dept. Florence, TX Title #01130945699250076	<b>Title or registration issued to insurance company</b> - Vehicle color noted as Black
03/20/2025		Audi	<b>Connect Service available with subscription</b>  <b>Connect offers services to enhance navigation, infotainment, and peace of mind</b>  <a href="#">Learn more</a>

Have Questions? Consumers, please visit our Help Center at [www.carfax.com](http://www.carfax.com). Dealers or Subscribers, please visit our Help Center at [www.carfaxonline.com](http://www.carfaxonline.com).

**CARFAX** Glossary

**Accident Indicator**

CARFAX receives information about accidents in all 50 states, the District of Columbia and Canada.

Not every accident is reported to CARFAX. As details about the accident become available, those additional details are added to the CARFAX Vehicle History Report. CARFAX recommends that you have this vehicle inspected by a qualified mechanic.

- According to the National Safety Council, Injury Facts, 2021 edition, 5% of the 276 million registered vehicles in the U.S. were involved in an accident in 2019. Over 77% of these were considered minor or moderate.
- This CARFAX Vehicle History Report is based only on information supplied to CARFAX and available as of 3/20/25 at 6:15:11 AM (CDT). Other information about this vehicle, including problems, may not have been reported to CARFAX. Use this report as one important tool, along with a vehicle inspection and test drive, to make a better decision about your next used car.

**Damage Severity**

Damage events result in one of the following severity levels:

- Minor: Generally, minor damage is cosmetic (including dents or scratches), may only require reconditioning, and typically does not compromise a vehicle's operation and/or safety.
- Moderate: Moderate damage may affect multiple components of the vehicle and may impair the vehicle's operation and/or safety.
- Severe: Severe damage usually affects multiple components of the vehicle and is likely to compromise the vehicle's operation and/or safety.

CARFAX recommends getting a pre-purchase inspection at a certified collision repair facility.

**First Owner**

When the first owner(s) obtains a title from a Department of Motor Vehicles as proof of ownership.

**New Owner Reported**

When a vehicle is sold to a new owner, the Title must be transferred to the new owner(s) at a Department of Motor Vehicles.

**Ownership History**

CARFAX defines an owner as an individual or business that possesses and uses a vehicle. Not all title transactions represent changes in ownership. To provide estimated number of owners, CARFAX proprietary technology analyzes all the events in a vehicle history. Estimated ownership is available for vehicles manufactured after 1991 and titled solely in the US including Puerto Rico. Dealers sometimes opt to take ownership of a vehicle and are required to in the following states: Maine, Massachusetts, New Jersey, Ohio, Oklahoma, Pennsylvania and South Dakota. Please consider this as you review a vehicle's estimated ownership history.

**Title Issued**

A state issues a title to provide a vehicle owner with proof of ownership. Each title has a unique number. Each title or registration record on a CARFAX report does not necessarily indicate a change in ownership. In Canada, a registration and bill of sale are used as proof of ownership.

**Total Loss Vehicle**

An insurance or fleet company declares a vehicle a total loss when a claim exceeds approximately 75% of its pre-damage value or if the vehicle is stolen and not recovered. This damage threshold varies by company. These companies typically take possession and obtain the title. Not all total loss vehicles result in a DMV-reported branded title. This may occur when an insurance company's definition of a total loss is different than the state DMV's definition for a branded title or when the owner of the vehicle is a self-insured company, like a fleet or rental company.

Follow Us: [facebook.com/CARFAX](https://facebook.com/CARFAX) [@CARFAXinc](https://twitter.com/CARFAXinc) [About CARFAX](#)

CARFAX DEPENDS ON ITS SOURCES FOR THE ACCURACY AND RELIABILITY OF ITS INFORMATION. THEREFORE, NO RESPONSIBILITY IS ASSUMED BY CARFAX OR ITS AGENTS FOR ERRORS OR OMISSIONS IN THIS REPORT. CARFAX FURTHER EXPRESSLY DISCLAIMS ALL WARRANTIES, EXPRESS OR IMPLIED, INCLUDING ANY IMPLIED WARRANTIES OF MERCHANTABILITY OR FITNESS FOR A PARTICULAR PURPOSE.

I have reviewed and received a copy of the CARFAX Vehicle History Report for this 2019 AUDI S5 SPORTBACK vehicle (VIN: WAUB4CF50KA079634), which is based on information supplied to CARFAX and available as of 3/20/25 at 7:15 AM (EDT).

---

Customer Signature

Date

---

Dealer Signature

Date