

2023 BMW 8 Series M850i Xdrive Gran Coupe

VIN: WBAGV8C08PCK80525

[Vehicle Details](#) ▾

CARFAX HAS THE MOST ACCIDENT & DAMAGE INFORMATION



BRANDED TITLE

⚠ Not Actual Mileage, Salvage

1 CARFAX 1-Owner Vehicle

🏠 Personal Lease Vehicle

📄 16 Detailed Records Available

This CARFAX Vehicle History Report is based only on [information](#) supplied to CARFAX and available as of 6/12/26 at 5:11:57 AM (CDT). Other information about this vehicle, including problems, may not have been reported to CARFAX. Use this report as one important tool, along with a vehicle inspection and test drive, to make a better decision about your next used car.

CARFAX Accident / Damage History

Not all accidents / issues are reported to CARFAX

Event 1

02/15/2023

Damage reported: minor damage ⓘ

Damage Severity Scale

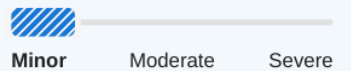

Event 2

06/11/2023

Accident reported

- It hit a curb
- It hit a stationary object
- Damage to undercarriage
- Disabling damage reported
- Vehicle towed
- Airbag deployed

[View More Details](#) >

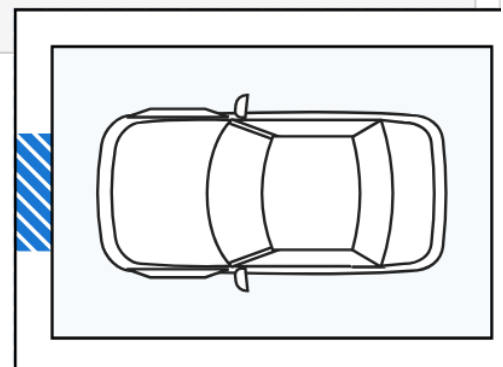

[View More Details >](#)

Event 3

06/11/2023

TOTAL LOSS VEHICLE

- Vehicle declared a total loss by an insurance company
- Collision damage reported

[View More Details >](#)

CARFAX Additional History

Not all accidents / issues are reported to CARFAX

Owner 1

Total Loss ⓘ

Total Loss Reported: 06/11/2023 and 01/09/2024.

[Total Loss Reported](#)

Structural Damage ⓘ

CARFAX recommends that you have this vehicle inspected by a collision repair specialist.



Airbag Deployment ⓘ

Airbag deployment reported: 06/11/2023.

[Airbag Deployment](#)

Odometer Check ⓘ

DMV title problems reported.

[Odometer Problem](#)

Accident / Damage ⓘ

DMV title problems reported. Damage reported: 02/15/2023. Accidents reported: 06/11/2023 and 01/09/2024.

[Severe Damage](#)

Manufacturer Recall ⓘ

No open recalls reported to CARFAX.

No Recalls Reported

Basic Warranty ⓘ

Original manufacturer warranty likely voided by manufacturer.

Warranty Voided

CARFAX Title History

Owner 1

Damage Brands ⓘ

Salvage | Junk | Rebuilt | Fire | Flood | Hail | Lemon

Alert!
Problem Found

Odometer Brands ⓘ

Not Actual Mileage | Exceeds Mechanical Limits

Alert!
Problem Found

ALERT! - Severe problems were reported by a state Department of Motor Vehicles (DMV). This vehicle does not qualify for the CARFAX Buyback Guarantee.

CARFAX Ownership History

The number of owners is estimated

Owner 1

Year purchased

2022

Type of owner

Personal Lease

Estimated length of ownership

1 yr. 3 mo.

Owned in the following states/provinces

New York

Owned in the following states/provinces	New York
Estimated miles driven per year	---
Last reported odometer reading	18,441

CARFAX Detailed History

[Glossary](#)

 **Owner 1**
Purchased: 2022

Personal Lease Vehicle

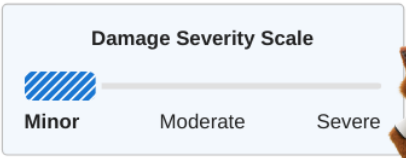
Date	Mileage	Source	Comments
Not Reported		BMW of North America, LLC	
08/05/2022	17	New York Inspection Station	Passed safety inspection -Emissions inspection performed
08/05/2022		New York Motor Vehicle Dept. Yonkers, NY	Registration issued or renewed -Titled or registered as personal lease vehicle -Passed safety inspection
08/09/2022	494	Inspection Co.	Inspection performed
08/19/2022		New York Motor Vehicle Dept. Hilliard, OH	Title issued or updated -First owner reported
08/21/2022		New York Motor Vehicle Dept. Hilliard, OH	Vehicle reported stolen
09/06/2022		New York Motor Vehicle Dept. Hilliard, OH	Title issued or updated -Vehicle recovered after theft
02/15/2023		Damage Report	Damage reported: minor damage 
<div style="text-align: center;"> <p>Damage Severity Scale</p>  </div>			
05/21/2023	17,249	New York Inspection Station	Passed safety inspection -Emissions inspection performed
06/11/2023		Damage Report	Accident reported -It hit a curb -It hit a stationary object -Damage to front -Damage to undercarriage -Disabling damage reported -Vehicle towed -Airbag deployed CARFAX Airbag Tips







CARFAX HAS THE MOST ACCIDENT & DAMAGE INFORMATION



Damage Location

FRONT
LEFT RIGHT
REAR



06/11/2023 		Damage Report	TOTAL LOSS VEHICLE -Vehicle declared a total loss by an insurance company -Collision damage reported
			There are many reasons an insurance company will declare a vehicle a total loss. Have this vehicle inspected by a qualified technician before you buy. Learn More
11/13/2023		New York Motor Vehicle Dept.	Title or registration issued to insurance company
11/13/2023 		New York Motor Vehicle Dept. Albany, NY	SALVAGE TITLE/CERTIFICATE ISSUED -NOT ACTUAL MILEAGE TITLE ISSUED
			A NAM title is issued when the owner discloses to a DMV mileage fraud, a broken odometer or that the actual mileage of this vehicle is unknown. Mileage reported after this reading is potentially unreliable.
11/22/2023 		Damage Report	SALVAGE TITLE/CERTIFICATE ISSUED
01/09/2024 	18,441	Damage Report	TOTAL LOSS VEHICLE -Vehicle declared a total loss by an insurance company -Collision damage reported
01/21/2024		Vehicle Exporter	Vehicle exported from -Newark, NJ and imported to -The Netherlands

Have Questions? Consumers, please visit our Help Center at www.carfax.com. Dealers or Subscribers, please visit our Help Center at www.carfaxonline.com.



Accident Indicator

CARFAX receives information about accidents in all 50 states, the District of Columbia and Canada.

Not every accident is reported to CARFAX. As details about the accident become available, those additional details are added to the CARFAX Vehicle History Report. CARFAX recommends that you have this vehicle inspected by a qualified mechanic.

- According to the National Safety Council, Injury Facts, 2021 edition, 5% of the 276 million registered vehicles in the U.S. were involved in an accident in 2019. Over 77% of these were considered minor or moderate.
- This CARFAX Vehicle History Report is based only on information supplied to CARFAX and available as of 6/12/26 at 5:11:57 AM (CDT). Other information about this vehicle, including problems, may not have been reported to CARFAX. Use this report as one important tool, along with a vehicle inspection and test drive, to make a better decision about your next used car.

Airbag Deployment

Occurs when the driver, passenger or side airbag has been used or deployed during a crash or other incident. If an airbag has been deployed, it must be replaced by a qualified technician. Have this car inspected by a mechanic prior to purchase.

Damage Indicator

Damage can be a result of many different types of events. Examples include contact with objects (other cars, trees, traffic signs, road debris, etc), vandalism, or weather-related events. Not every damage event is reported to CARFAX. As details about the damage event become available, those additional details are added to the CARFAX Vehicle History Report. CARFAX recommends that you have this vehicle inspected by a qualified mechanic.

- This CARFAX Vehicle History Report is based only on information supplied to CARFAX and available as of 6/12/26 at 5:11:57 AM (CDT). Other information about this vehicle, including problems, may not have been reported to CARFAX. Use this report as one important tool, along with a vehicle inspection and test drive, to make a better decision about your next used car.

Damage Severity

Damage events result in one of the following severity levels:

- Minor: Generally, minor damage is cosmetic (including dents or scratches), may only require reconditioning, and typically does not compromise a

- Minor: Generally, minor damage is cosmetic (including dents or scratches), may only require reconditioning, and typically does not compromise a vehicle's operation and/or safety.
- Moderate: Moderate damage may affect multiple components of the vehicle and may impair the vehicle's operation and/or safety.
- Severe: Severe damage usually affects multiple components of the vehicle and is likely to compromise the vehicle's operation and/or safety.

CARFAX recommends getting a pre-purchase inspection at a certified collision repair facility.

Federal Odometer Act

The Federal Odometer Act requires a seller to disclose the vehicle's mileage on the title when ownership is transferred. Congress enacted this Act to prohibit odometer tampering and to protect consumers from mileage fraud. Under this act, sellers must disclose any issues with the vehicle's odometer. These disclosures translate into the Exceed Mechanical Limits and Not Actual Mileage titles.

First Owner

When the first owner(s) obtains a title from a Department of Motor Vehicles as proof of ownership.

Not Actual Mileage Title

When the seller certifies, under the Federal Odometer Act, that the odometer reading does not reflect the vehicle's actual mileage. This may occur because the odometer was tampered with, broken, or replaced.

Ownership History

CARFAX defines an owner as an individual or business that possesses and uses a vehicle. Not all title transactions represent changes in ownership. To provide estimated number of owners, CARFAX proprietary technology analyzes all the events in a vehicle history. Estimated ownership is available for vehicles manufactured after 1991 and titled solely in the US including Puerto Rico. Dealers sometimes opt to take ownership of a vehicle and are required to in the following states: Maine, Massachusetts, New Jersey, Ohio, Oklahoma, Pennsylvania and South Dakota. Please consider this as you review a vehicle's estimated ownership history.

Salvage Title

A Salvage Title is issued on a vehicle damaged to the extent that the cost of repairing the vehicle exceeds approximately 75% of its pre-damage value. This damage threshold may vary by state. Some states treat Junk titles the same as Salvage but the majority use this title to indicate that a vehicle is not road worthy and cannot be titled again in that state. The following eleven states also use Salvage titles to identify stolen vehicles - AZ, FL, GA, IL, MD, MN, NJ, NM, NY, OK and OR.

Title Issued

A state issues a title to provide a vehicle owner with proof of ownership. Each title has a unique number. Each title or registration record on a CARFAX report does not necessarily indicate a change in ownership. In Canada, a registration and bill of sale are used as proof of ownership.

Total Loss Vehicle

An insurance or fleet company declares a vehicle a total loss when a claim exceeds approximately 75% of its pre-damage value or if the vehicle is stolen and not recovered. This damage threshold varies by company. These companies typically take possession and obtain the title. Not all total loss vehicles result in a DMV-reported branded title. This may occur when an insurance company's definition of a total loss is different than the state DMV's definition for a branded title or when the owner of the vehicle is a self-insured company, like a fleet or rental company.

Follow Us:



CARFAX DEPENDS ON ITS SOURCES FOR THE ACCURACY AND RELIABILITY OF ITS INFORMATION. THEREFORE, NO RESPONSIBILITY IS ASSUMED BY CARFAX OR ITS AGENTS FOR ERRORS OR OMISSIONS IN THIS REPORT. CARFAX FURTHER EXPRESSLY DISCLAIMS ALL WARRANTIES, EXPRESS OR IMPLIED, INCLUDING ANY IMPLIED WARRANTIES OF MERCHANTABILITY OR FITNESS FOR A PARTICULAR PURPOSE.

© 2026 CARFAX, Inc., part of S&P Global. All rights reserved.
6/12/26 5:11:57 AM (CDT)

I have reviewed and received a copy of the CARFAX Vehicle History Report for this 2023 BMW 8 SERIES vehicle (VIN: WBAGV8C08PCK80525), which is based on information supplied to CARFAX and available as of 6/12/26 at 6:11 AM (EDT).

Customer Signature

Date

Dealer Signature

Date